

1. Start at end of arena. Run down middle past center marker to a sliding stop. Back at least 10 feet to center. ¼ turn left.
2. Beginning on the right lead, complete 2 circles to the right. The first one large and fast, the second small and slow. Change leads at the center of arena.
3. Complete 2 circles to the left. The first circle large and fast, the second circle small and slow. Change leads at the center of arena.
4. Continue around end of arena without breaking gait or changing leads, run down the side (approximately 20 feet from fence) past center marker and come to a sliding stop.
5. Complete 3½ spins to the right.
6. Continue back down side and end of arena to other side (approximately 20 feet from fence) go past center marker and come to a sliding stop.
7. Complete 3½ spins to the left. Hesitate to complete pattern.

PATTERN 2

LOPE AWAY

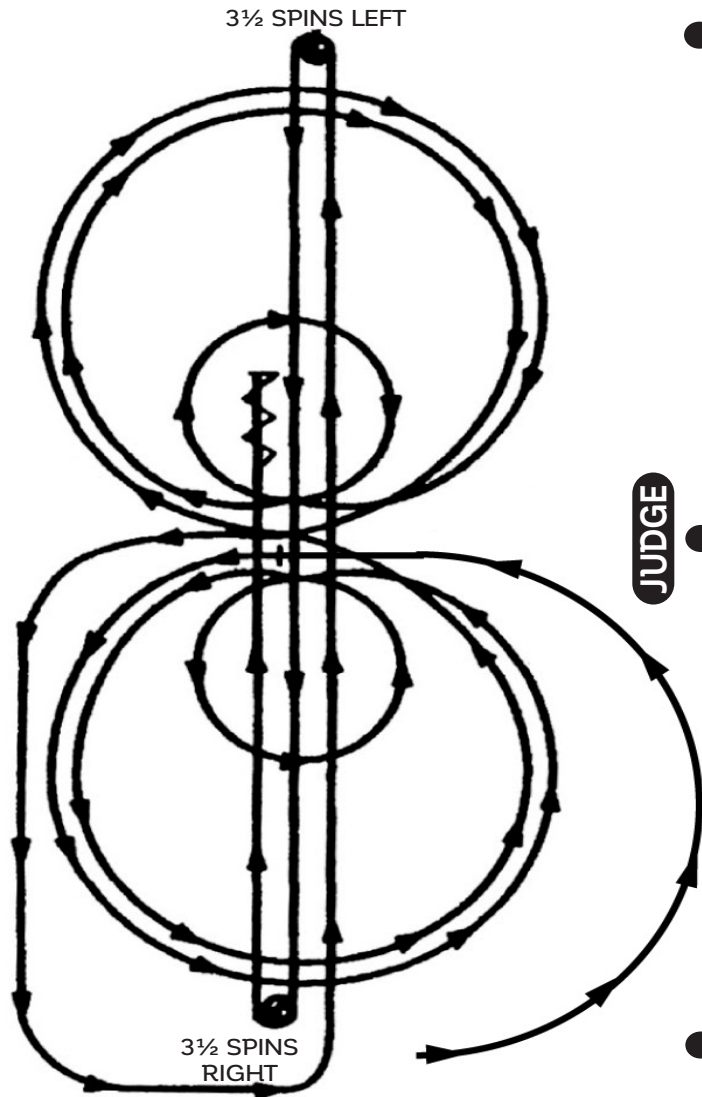

Begin on left lead. At the center, without stopping or breaking gait, begin pattern facing away from the judge. Refer to rule 20.6

1. Beginning on the left lead, complete 3 circles to the left. The first one large and fast, the second small and slow, the third large and fast. Change leads at the center of arena.
2. Complete 3 circles to the right. The first one large and fast, the second small and slow, and the third large and fast. Change leads at the center of arena.
3. Continue loping to run down. Run to far end past the marker to a sliding stop.
4. Complete 3½ spins to the left.
5. Run to far end past marker to a sliding stop.
6. Complete 3½ spins to the right.
7. Run past center marker to a sliding stop. Back at least 10 feet. Hesitate to complete pattern.

PATTERN 3

LOPE TOWARD

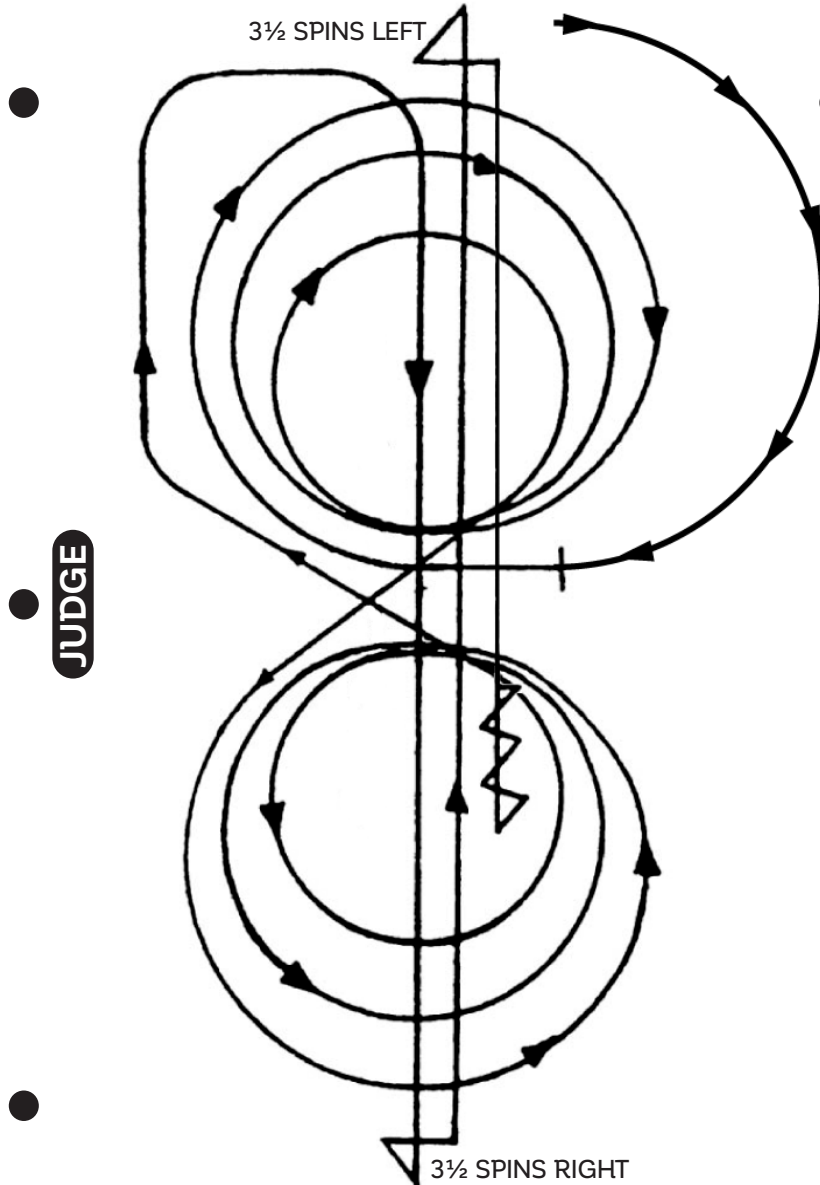

● Begin on right lead. At the center, without stopping or breaking gait, begin pattern facing toward the judge. Refer to rule 20.6.

1. Begin on right lead complete three circles to right, two large fast circles followed by one small and slow circle, change to left lead.
2. Complete three circles to left, two large fast circles followed by one small and slow circle. Change to right lead.
3. Continue loping around end of arena without breaking gait. Run up center of arena to far end past the end marker and come to a sliding stop.
4. Complete $3\frac{1}{2}$ spins to the right.
5. Run up center of arena past the end marker, and come to a sliding stop.
6. Complete $3\frac{1}{2}$ spins to the left.
7. Run back to middle of the arena past the center marker and come to a sliding stop. Back at least 10 feet in a straight line. Hesitate to complete pattern.

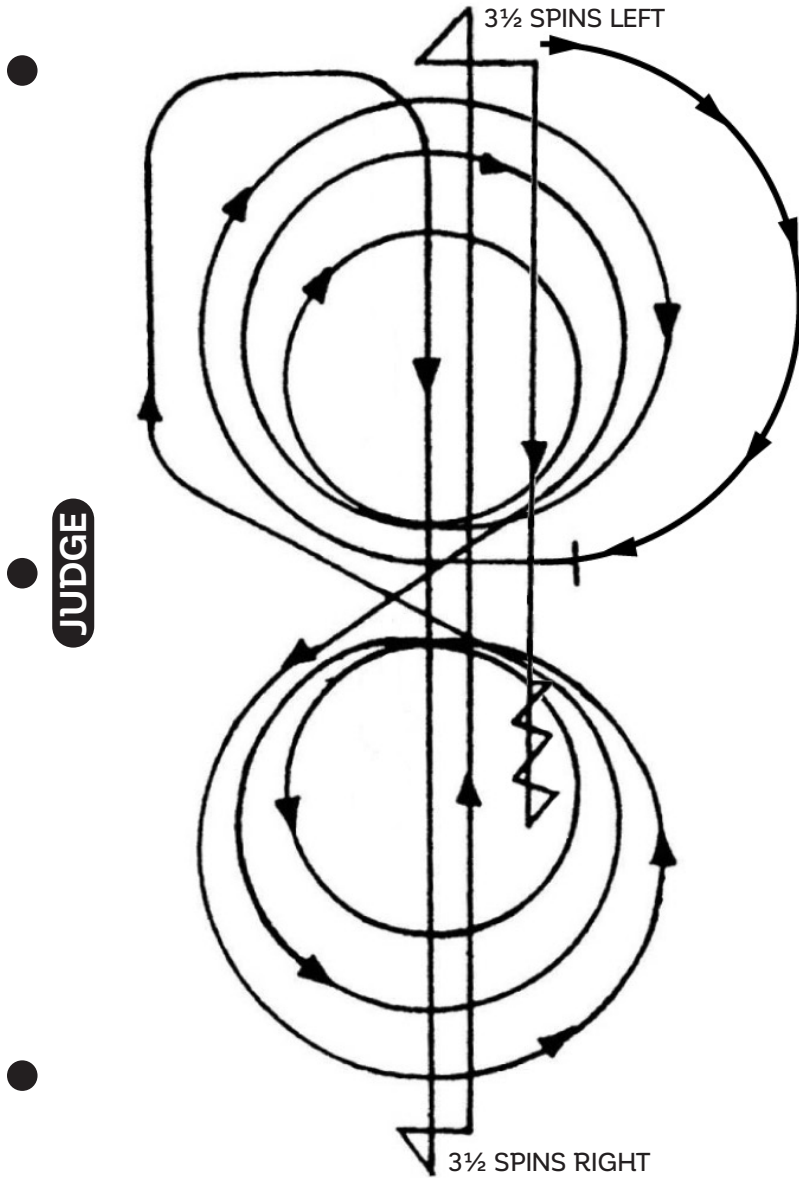

Begin on right lead. At the center, without stopping or breaking gait, begin pattern facing toward the judge. Refer to rule 20.6.

1. Beginning on right lead and complete three circles, the first large and fast, the second small and slow, the third large and fast. Change leads to the left.
2. Complete three circles, the first large and fast, the second small and slow, the third, large and fast. Change leads to the right.
3. Continue loping around end of arena without breaking gait or changing leads. Run down center of arena, past end marker and come to a sliding stop.
4. Complete $3\frac{1}{2}$ spins to the right.
5. Run down center of arena past end marker come to sliding stop.
6. Complete $3\frac{1}{2}$ spins to the left.
7. Run past center marker come to sliding stop. Back up at least 10 feet. Hesitate to complete pattern.

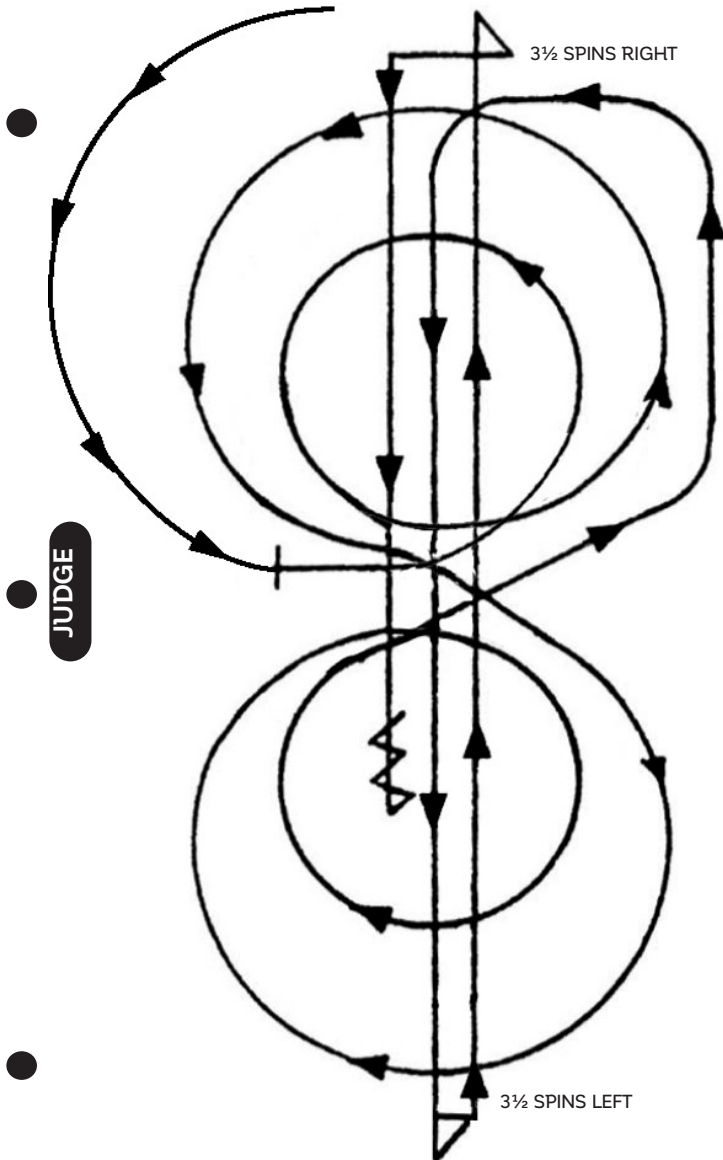

Start on left lead. At the center, without stopping or breaking gait, begin pattern facing away from the judge. Refer to rule 20.6.

1. Beginning on the left lead, complete two circles to the left. The first circle small and slow, the second circle large and fast. Change leads at the center of arena.
2. Complete two circles to the right. The first circle large and fast, the second circle small and slow. Change leads at the center of arena.
3. Continue around end of arena without breaking gait or changing leads, run down center of arena past end marker, and execute a square sliding stop.
4. Complete 3½ spins to the left.
5. Run down center of arena past end marker, and execute a square sliding stop.
6. Complete 3½ spins to the right.
7. Run down center of arena past center marker, and execute a square sliding stop. Back up at least 10 feet. Hesitate to complete pattern.

RANCH RIDING - PATTERN 4

LEGEND

| | |
|---------|---------------|
| | Walk |
| | Extended Walk |
| - - - | Trot |
| - - - - | Extended Trot |
| — — — | Lope |
| — — — — | Extended Lope |
| //// | Back |
| // | Lead Change |

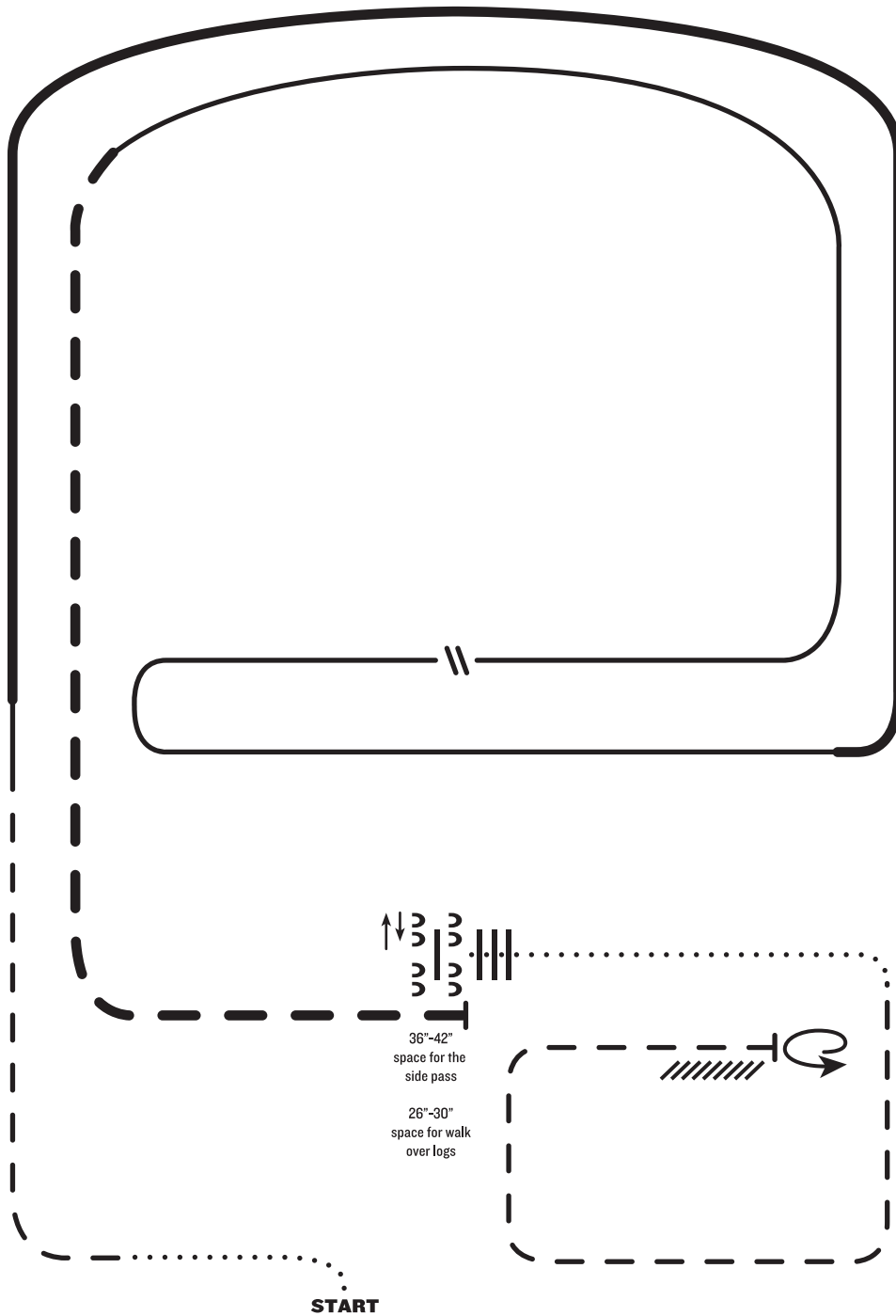

1. Walk
2. Trot
3. Extended lope right lead
4. Lope right lead
5. Change leads (simple or flying)
6. Lope left lead
7. Extended trot
8. Stop, side pass left, side pass right, 1/2 way
9. Walk over logs
10. Walk
11. Trot square
12. Stop, 360° turn left, and back

Note: The drawn description of this pattern is only intended for the general depiction of the pattern. Exhibitors should utilize the arena space to best exhibit their horses.